

D E P A R T M E N T O F T H E A R M Y T E C H N I C A L M A N U A L

**General Support and Depot Maintenance Repair Parts and Special
Tools Lists
NIGHT VISION SIGHTS, MINIATURIZED AN/PVS-3 AND AN/PVS-3A
(FSN 5855-832-9341 and FSN 5855-156-4992)**

Current as of 13 October 1971

Headquarters, Department of the Army, Washington, D.C.
18 April 1972

	Paragraph	Page
Section I. INTRODUCTION		
Scope	1-1	1-1
General	1-2	1-1
Explanation of columns.	1-3	1-1
Special information	1-4	1-2
Location of repair parts	1-5	1-2
Federal supply codes for manufacturers	1-6	1-2
Recommendations for maintenance publications improvements	1-7	1-3
II. REPAIR PARTS FOR DIRECT SUPPORT, GENERAL SUPPORT, AND DEPOT MAINTENANCE		2-1
SPECIAL TOOLS, TEST, AND SUPPORT EQUIPMENT FOR DIRECT SUPPORT, GENERAL SUPPORT, AND DEPOT MAINTENANCE (not applicable).		
III. INDEX-FEDERAL STOCK NUMBER CROSS-REFERENCES TO FIGURE AND ITEM NUMBER OR REFERENCE DESIGNATION		3-1
IV. INDEX-REFERENCE DESIGNATION CROSS-REFERENCE TO PAGE NUMBER		4-1

LIST OF ILLUSTRATIONS

Figure No.	Title	Page
1	Carrying case, sight, and accessories	2-10
2	Night Vision Sights, Miniaturized AN/PVS-3 and AN/PVS-3A	2-10
3	Boresight assembly removal	2-11
4	Night Vision Sight, Miniaturized AN/PVS-3	2-12
5	Boresight assembly	2-13
6	Battery tray assembly	2-14
7	Eyepiece assembly	2-14
8	Eyepiece assembly, exploded view	2-15
9	Focusing tube assembly, exploded view	2-16
10	Objective lens assembly, view 1	2-17
11	Objective lens assembly, view 2	2-17
12	Housing assembly, exploded view	2-18
13	Receiver mount assembly M14	2-18
14	Receiver mount assembly M16	2-18

*This manual supersedes TM 11-5855-209-45P, 11 July 1969.

Section I.

INTRODUCTION

1-1. Scope

This manual lists repair parts required for the performance of general support and depot maintenance of the AN/PVS-3 and AN/PVS-3A.

1-2. General

This repair parts list is divided into the following:

a. Repair Parts-Section II. A list of repair parts authorized for the performance of maintenance at general support and depot level.

b. Index-Federal Stock Number Cross-Reference to Figure and Item Number or Reference Designation-Section III. A list of Federal stock numbers in ascending numerical sequence, followed by a list of reference numbers, in ascending alphanumeric sequence, cross-referenced to the figure number and reference designation or item number.

c. Index—Reference Designation Cross-Reference to Page Number-Section IV. A list of reference designations cross-referenced to page numbers.

1-3. Explanation of Columns

The following provides an explanation of columns in the tabular lists:

a. Source, Maintenance, and Recoverability Codes (SMR), Column 1.

(1) Source codes indicate the selection status and source for the listed item. Source codes used are -

<i>Code</i>	<i>Explanation</i>
P-	Repair parts which are stocked in or supplied from the GSA/DSA or Army supply system and authorized for use at indicated maintenance categories.
P2-	Repair parts which are procured and stocked for insurance purposes because the combat or military essentiality of the end item dictates that a minimum quantity be available in the supply system.
P9-	Assigned to items which are NSA design controlled: unique repair parts, special tools, test, measuring and diagnostic equipment, which are stocked and supplied by the Army COMSEC logistic system, and which are not subject to the provisions of AR 380-41.
P10-	Assigned to items which are NSA design controlled: special tools, test, measuring and diagnostic equipment for COMSEC support, which are accountable under the provisions of AR 380-41, and which are

<i>Code</i>	<i>Explanation</i>
	stocked and supplied by the Army COMSEC logistic system.
M-	Repair parts which are not procured or stocked, but are to be manufactured at indicated maintenance levels.
A-	Assemblies which are not procured or stocked as such, but are made up of two or more units. Such component units carry individual stock numbers and descriptions, are procured and stocked separately and can be assembled to form the required assembly at indicated maintenance categories.
X-	Parts and assemblies which are not procured or stocked and the mortality of which normally is below that of the applicable end item or component. The failure of such part or assembly should result in retirement of the end item from the supply system.
X1-	Repair parts which are not procured or stocked. The requirement for such items will be filled by use of the next higher assembly or component.
X2-	Repair parts which are not stocked. The indicated maintenance category requiring such repair parts will attempt to obtain same through cannibalization. Where such repair parts are not obtainable through cannibalization, requirements will be requisitioned, with accompanying justification through normal supply channels.
G-	Major assemblies that are procured with PEMA funds for initial issue only as exchange assemblies at DSU and GSU level. These assemblies will not be stocked above DS and GS level or returned to depot supply level.

(2) Maintenance codes indicate the lowest category of maintenance authorized to install the listed item. The maintenance level codes are-

<i>Code</i>	<i>Explanation</i>
O.....	Organizational maintenance
F.....	Direct support maintenance
H.....	General support maintenance
D.....	Depot maintenance

(3) Recoverability codes indicate whether un-serviceable items should be returned for recovery or salvage. Items not coded are expendable. Recoverability codes are-

<i>Code</i>	<i>Explanation</i>
R -	Repair parts and assemblies that are economically repairable at DSU and GSU activities and are normally furnished by supply on an exchange basis.
S -	Repair parts and assemblies which are economically repairable at DSU and GSU activities and which normally are furnished by supply on an exchange basis. When items are determined by a GSU to be uneconomically repairable, they will be evacuated to a depot for evaluation and analysis before final disposition.
T -	High-dollar value recoverable repair parts which are subject to special handling and are issued on an exchange basis. Such repair parts normally are repaired or overhauled at depot maintenance activities:
U -	Repair parts specifically selected for salvage by reclamation units because of precious metal content, critical materials, or high-dollar value reusable casings or castings.

b. Federal Stock Number, Column 2. This column indicates the Federal stock number assigned to the item and will be used for requisitioning purposes.

c. Description, Column 3. This column indicates the Federal item name and any additional description of the item required. The index number has been included as part of the description to aid in the location of "same as" items. A part number or other reference number is followed by the applicable five-digit Federal supply code for manufacturers in parentheses.

d. Unit of Measure (U/M), Column 4. A 2-character alphabetical abbreviation indicating the amount or quantity of the item upon which the allowances are based, e.g., ft, ea, pr, etc.

e. Quantity Incorporated in Unit, Column 5. This column indicates the quantity of the item used in the AN/PVS-3 and AN/PVS-3A. A "V" appearing in this column in lieu of a quantity indicates that a definite quantity cannot be indicated (e.g., shims, spacers, etc.). Subsequent appearances of the same item in the same subassembly are indicated by the letters "REF."

f. Allowances 30-Day (GS Maintenance, 1 Year Per Equipment (Contingency), and Depot Maintenance). Items authorized for requisition as required are identified by an asterisk in the allowance column.

g. Illustrations.

(1) *Figure number.* Indicates the figure number in which the item is shown.

(2) *Item number or reference designation.* Indicates the reference designation or item number used to identify the item in the illustration.

1-4. Special Information

a. Identifications of the usable on codes included in column 3 of section II are-

<i>Code</i>	<i>Used on-</i>
1	AN/PVS-3
2	AN/PVS-3A

b. The following publications pertain to the AN/PVS-3 and AN/PVS-3A:

- TM 11-5855-209-10 . . Operator's Manual: Night Vision Sights AN/PVS-3 and AN/PVS-3A.
- TM 11-5855-209-23 . . Organizational and DS Maintenance Manual Including Repair Parts and Special Tool Lists: Night Vision Sights, Miniaturized AN/PVS-3 and AN/PVS-3A (FSN 5855-832-9341; 5855-156-4992).

1-5. Location of Repair Parts

a. This manual contains two cross-reference indexes (secs. III and IV) to be used to locate a repair part when either the Federal stock number, reference number (manufacturer's part number) or reference designation is known. The first column in each index is prepared in numerical or alphanumeric sequence in ascending order. Where a Federal stock number is not listed, refer to the reference number (manufacturer's part number) immediately following the Federal stock number.

b. When the Federal stock number or reference number is known, follow the procedures given in (1) and (2) below.

(1) Refer to the index of Federal stock numbers (sec. III) and locate the Federal stock number or reference number. The Federal stock number or reference number is cross-referenced to the applicable figure and reference designation or item number.

(2) When the reference designation is determined, refer to the reference designation index (sec. IV). The reference designations are listed in numeric-alpha ascending order and are cross-referenced to the page number on which they appear in the repair parts list (sec. II). Refer to the page number noted in the index and locate the reference designation in the repair parts list (col. 10b). If the *Description* column indicates that it is a "SAME AS" item, locate the first appearance of the item by the index number referenced.

1-6. Federal Supply Code for Manufacturers

<i>Code</i>	<i>Manufacturer</i>
01139 . .	General Electric Company
04963 . .	Minnesota Mining and Manufacturing Company

Code

Manufacturer

71984 Dow Corning Corporation
80063 Army Electronics Command
80205 National Aerospace Standards
81348 Federal Specifications
81349 Military Specifications
96906 Military Standards

1-7. Recommendations for Maintenance Publications Improvements

The reporting of errors, omissions, and recommendations for improving this publication by the individual user is encouraged. Reports should be submitted on DA Form 2028 (Recommended Changes to Publications) and forwarded direct to Commanding General, US Army Electronics Command, ATTN: AMSEL-MA-S, Fort Monmouth, N.J. 07703.

SECTION II REPAIR PARTS FOR DIRECT SUPPORT, GENERAL SUPPORT, AND DEPOT MAINTENANCE

(1) S R O D E	(2) F E D E R A L S T O C K N U M B E R	(3) D E S C R I P T I O N R E F E R E N C E N U M B E R & M F R C O D E	(4) Q U A N T I T Y O F I E M S	(5) U N I T O F M E A S U R E	(6) 30-DAY DS ALLOWANCE				(7) 3S			(8) Y R P E R I O D I N T E R V A L (Y C Y)	(9) P O T E N T I A L L I F E S P A N (Y C Y)	(10) I L L U S T R A T I O N S (b) I T E M N O. O R R E F E R E N C E D E S I G N A T I O N	
					a) 20	b) -50	c) 10	IT	0-	3S M A X	IT				
															d) 20
	855-832-9341	1001 NIGHT VISION SIGHT, MINIA-TURIZED AN/PVS-3: (INCLUDES MWO 11-5855-209-30/1) (This item is nonexpendable)	1											1	
	855-156-4992	1001A NIGHT VISION SIGHT, MINIA-TURIZED AN/PVS-3A (This item is nonexpendable)	2											1	
O-S	855-167-7697	1002 NIGHT VISION SIGHT SUBASSEMBLY MX-8201/PVS-3: (INCLUDES MWO 11-5855-209-30/1) (This item is nonexpendable)	1	SA	1										
O-S	855-156-4993	1002A NIGHT VISION SIGHT SUBASSEMBLY MX-8201 A/PVS-3: (This item is nonexpendable)	2	SA	1									2	
F-T	855-054-8540	1003 OBJECTIVE LENS ASSEMBLY: SCD635077-1 (80063)	1,2	SA	1				*	*			*	3	1
D	855-168-1500	1004 SHADE, EXTERNAL: SCD635118 (80063)	1,2	SA	1								*	0	1
D	855-168-1498	1005 RING, RETAINING: SCC635117 (80063)	1,2	SA	1								*	0	
D	855-167-7894	1006 LENS, OPT, ELEM: SCC635111-1 (80063)	1,2	SA	1								*	0	
D	330-134-3106	1007 PACKING, PREFMD: SCB635078 (80063)	1,2	SA	1								*	0	
D	855-168-1501	1008 SPACER, LENS: SCC635093 (80063)	1,2	SA	1								*	0	
D	855-167-7970	1009 LENS, OPT ELEM: SCC635112-1 (80063)	1,2	SA	1								*	0	3
D	855-168-1503	1010 SPACER, LENS: SGB635089 (80063)	1,2	EA	1								*	0	3
D	855-167-7971	1011 LENS, OPT ELEM: SCC635113-1 (80063)	1,2	EA	1								*	0	10
D	855-168-1508	1012 SHADE, MIRROR: SCD635095-1 (80063)	1,2	EA	1								*	0	11
D	855-168-1497	1013 MIRROR, PRIMARY: SCC635116 (80063)	1,2	EA	1								*	0	12
D	855-168-1499	A014 RING, RETAINING: SCC635084 (80063)	1,2	EA	1								*	0	13
D	855-167-7974	A015 LENS, OPT ELEM: SCC635114-1 (80063)	1,2	EA	1								*	0	14
D	365-477-3899	A016 SPACER, LENS: SCB635099 (80063)	1,2	EA	1								*	0	15
D	855-167-7966	A017 LENS, OPT ELEM: SCC635115-1 (80063)	1,2	EA	1								*	0	16
D	855-167-7944	A018 HOUSING, OBJV LENS: SCD635094-1 (80063)	1,2	EA	1								*	0	2
I-D		A019 HOUSING: SCD635094-2 (80063)	1,2	EA	1										1A1A1MP1
D	5340-443-587	A020 INSERT, SCR THD: MS51830-102L (96906)	1,2	EA	6								*	*	1A1A1MP2
D	5340-443-587	A021 INSERT, SCR THD: SAME AS A020	1,2	EA	REF								*	*	1A1A1MP3
D	5340-443-587	A022 INSERT, SCR THD: SAME AS A020	1,2	EA	REF								*	*	1A1A1MP4
D	5340-443-587	A023 INSERT, SCR THD: SAME AS A020	1,2	EA	REF								*	*	1A1A1MP5
D	5340-443-587	A024 INSERT, SCR THD: SAME AS A020	1,2	EA	REF								*	*	1A1A1MP6
D	5340-443-587	A025 INSERT, SCR THD: SAME AS A020	1,2	EA	REF								*	*	1A1A1MP7

SECTION II REPAIR PARTS FOR DIRECT SUPPORT, GENERAL SUPPORT, AND DEPOT MAINTENANCE (CONTINUED)

(1) SMF CODE	(2) FEDERAL STOCK NUMBER	(3) DESCRIPTION REFERENCE NUMBER & MFR. CODE	USABLE ON CODE	(4) UNIT OF MEAS	(5) QTY IN UNIT	(6) 30-DAY DS MAINT ALLOWANCE			(7) 30- GS INT OWANC			(8) W O NT	(9) EPO INI WPI OO JULI	(10) ILLUSTRATIONS (a) IC NO.	(b) ITEM NO. OR REFERENCE DESIGNATION
						(a) -2C	(b) I-5C	(c) -1C	(a) -2C	(b) I-50	(c) -1C				
P-D	1330-585-9772	A026 PACKING, PREFND : MS28775-001 (96906)	1, 2	EA	1						*	*	10	17	
P-D	1305-728-5496	A027 SETSCREW : MS51973 -21 (96906)	1, 2	EA	1						*	*	10		
P-D	1855	A028 SEALING CMPD : EC612 (04963)	1, 2	CN	V						*	*		1A1MP19	
P-D	7510	A030 TAPE, PRESSURE- SENSITIVE : L190TYPE2CLASSA (81348)	1, 2	RO							*	*		1A1MP21	
P-D	1030-275-8116	A031 SEALING CMPD : MILS7502CLASSA2 (81349)	1, 2	CN	V						*	*		1A1MP22	
P-D		A032 SEALING, LKG AND RING CMPD : MILS22473GRADECV (81349)	1, 2	CN	V						*	*		1A1MP23	
P-F-1	1855-433-2348	A033 BODY ASSEMBLY : SCD635053-2 (80063)	2	EA	1			*	*	*	*	*	3		
P-F-1		A033A BODY ASSEMBLY : SC-D-635053-1 (80063)	1	EA	1			*	*	*	*	*	4	2	
11-D		A034 HOUSING ASSY : SCD635055-2 (80063)		EA	1								12	1A2A1	
11-D		A034A HOUSING ASSEMBLY : SC-D-635055-1 (80063)	1	EA	1								12		
P-D	1855-054-8618	A035 PRINTED WIRING BOARD AS SEMBL) SCB635081 (80063)	1, 2	EA	1						*	*	12	1A2A1A1	
11-D		A036 PRINTED WIRING BOARD : SCD635120 (80063)	1, 2	EA	1								12	11	
11-D		A037 CONTACT, ELEC : SCC635122 (80063)	1, 2	EA	1								12	18	
11-D		A038 EYELET, METALLIC : NAS1453-3-0645 (80205)	1, 2	EA	4								12	17	
P-F	1135-491-5252	A041 COVER ASSEMBLY : SCC635075-1 (80063)	1, 2	EA	1			*	*	*	*	*	12	1A2A1A2	
P-F	1305-880-6896	A042 SCREW, KNURLED : SCB635082 (80063)	1, 2	EA	1			*	*	*	*	*	4		
P-F	1305-880-6895	A043 SCREW, SHOULDER : SCB635064 (80063)	1, 2	EA				*	*	*	*	*	4	30	
P-F	1310-880-9367	A044 NUT, KNURLED : SCB635065 (80063)	1, 2	EA	1			*	*	*	*	*	12	5	
P-F	1315-880-8975	A045 PIN, SLOTTED : SCB635066 (80063)	1, 2	EA	1			*	*	*	*	*	12	1	
11-D		A046 GASKET : SCC635121 (80063)	1, 2	EA									12		
11-D		A047 COVER, BATTERY : SCD635088 (80063)	1, 2	EA									12	3	
P-D	1040-828-7385	A048 ADHESIVE : SCB614454-2 (80063)	1, 2	U	V						*			1A2A1A2MP3	
11-D		A049 HOUSING SUBASSY : SCD635061-2 (80063)	2	EA									12		
P-D	1855-167-7700	A049A HOUSING SUBASSEMBLY : SC-D-635061-1 (80063)	1	EA							*	*	12	2	
11-D		A050 HOUSING : SCD635061-4 (80063)	2	EA										1A2 A1A3MP1	
11-D		A050A HOUSING : SC-D-635061-3 (80063)	1	EA											
11-D		A051 INSERT, SCR THD : MS21208C410 (96906)		EA										1A2A1A3MP2	
11-D		A052 INSERT, SCR THD : SAME AS A051		EA	1E1									1A2A1A3MP3	
11-D		A052A INSERT : NAS1395 C-06 (80205)		EA	1										

SECTION II REPAIR PARTS FOR DIRECTSUPPORT, AND DEPOT MAINTENANCE (CONTINUED)

(1) SNF COD	(2) FEDERAL STOCK NUMBER	(3) DESCRIPTION REFERENCE NUMBER & MFR. CODE	USABLE QTY CODE	OF MEA:	QTY REQ UNIT	(6) 30-DAY DS MAINT ALLOWANCE			(7) G OWA INT			(8) Y LWPI EQUI MTGC	(9) EPC AIM WP 100 Q1	(10) ILLUSTRATIONS (b) ITEM NO. OR REFERENCE DESIGNATION
						(a) 1-2	(b) 1-5	(c) 1-1	(d) 1-1	(e) 1-1	(f) 1-1			
-D	5855-167-770	A053 CONTACT,ELEC: SCC635125 (80063)	1,2	EA	1						*	*	14	
-D		A054 RIVET,INSULET: SCB635131 (80063)	1,2	EA	2								8	
-D		A055 INSULATOR,CONT: SCB635124 (80063)	1,2	EA	1								15	
-F	5930-937-213	A056 SWITCH,TOGGLE: SCC607138 (80063)	1,2	EA	1				*	*	*	*	12	
-F	8030-081-232	A057 SEALING,LKG,AND RTNG CMPD: MILS22473GRADEH (81349)	1,2	CN	V				*	*	*	*	1A2A1MP1	
-D	8040-855-576	A058 ADHESIVE,EPOXY: MILA14042 (81349)	1,2	CN	V						*	*	1A2A1MP2	
-D	8030-275-811	A059 SEALING CMPD: SAME AS A031	1,2	CN	V						*	*	1A2A1MP3	
F	5855-433-234	A060 TUBE FOCUSING ASSEMBLY: SCD635054-2 (80063)	2	EA	1				*	*	*	*	6	
F	5855-054-850	TUBE ASSEMBLY: SC-D-635054-1 (8 0063)	1	EA	1				*	*	*	*	6	
-D		A061 TUBE,FOCUSING: SCD635060-2 (80063)	2	EA	1								6	
-D		A061A TUBE,FOCUSING: SC-D-635060-1 (80063)	1	EA	1								6	
F	5855-167-770	A062 SPACER, IMAGE INTENSIFIER TUBE: SCB635067 (80063)	1,2	EA	1				*	*	*	*	5	
D	5935-167-784	A063 CONTACT,GROUND: SCB635086 (80063)	1,2	EA	1						*	*	3	
D		A064 RIVET,TUBULAR: MS16535-11 (96906)	1,2	EA	1						*	*	7	
D	5935-167-784	A065 CONTACT,ELEC: SCC635068 (80063)	1,2	EA	1						*	*	1	
D	5320-792-324	A066 RIVET,INSULET: SCB635076 (80063)	1,2	EA	2						*	*	8	
D	5970-935-814	A067 INSULATOR: SCB635070 (8 0063)	1,2	EA	1						*	*	2	
D		A067A SCALE,DIOPTER: SC-C-635085 (80063)	1	EA	1									
F	5855-167-769	A068 COUPLER,RING: SCD635069 (80063)	1,2	EA	1				*	*	*	*	9	
F	5330-802-136	A069 PACKING,PREFMD: SCB635059-5 (80063)	1,2	EA	1				*	*	*	*	15	
F	5855-133-877	A070 SCREW,GUIDE: SCB635119 (80063)	1,2	EA	1				*	*	*	*	21	
F	5305-239-785	A071 SETSCREW: SCB635087-1 (80063)	1,2	EA	4				*	*	*	*	19	
F	5305-239-785	A072 SETSCREW: SAME AS A071	1,2	EA	EF				*	*	*	*	1A2H3	
F	5305-239-785	A073 SETSCREW: SAME AS A071	1,2	EA	EF				*	*	*	*	1A2H4	
F	5305-239-785	A074 SETSCREW: SAME AS A071	1,2	EA	EF				*	*	*	*	1A2H5	
F	5305-812-578	A075 SETSCREW: SCB635087-3 (80063)	1,2	EA	4				*	*	*	*	18	
F	5305-812-578	A076 SETSCREW: SAME AS A075	1,2	EA	EF				*	*	*	*	1A2H7	
F	5305-812-578	A077 SETSCREW: SAME AS A075	1,2	EA	EF				*	*	*	*	1A2H8	
F	5305-812-578	A078 SETSCREW: SAME AS A075	1,2	EA	EF				*	*	*	*	A2H9	

SECTION II REPAIR PARTS FOR DIRECT SUPPORT, GENERAL SUPPORT, AND DEPOT MAINTENANCE (CONTINUED)

(1) SMR CODE	(2) FEDERAL STOCK NUMBER	(3) DESCRIPTION REFERENCE NUMBER & MFR. CODE	(4) UNIT OF MEAS	(5) QTY REQ UN	31 DS INT			(7)			(8) I Y W P DU ITGC	(9) EPC AIN W P 100 DU	(10) ILLUSTRATIONS (b) ITEM NO. OR REFERENCE DESIGNATION		
					USABLE ON CODE	CN	V	30- G: DNI	NT	(a) -20				(b) -30	(c) -1
-F	850-295-768	A079 SILICONE CMPD: MILS8660 (80063)	1,2	CN	V				*	*	*	*	*	1A2MP3	
-F-	855-409-092	A080 EYEPiece ASSY: SCD635079-2 (80063)	1,2	EA	1				*	*	*	*	*	4 5	
-O	855-925-0114	A081 EYESHIELD ASSY: SCD614703 (80063)	1,2	EA	1				*	*	*	*	*	4 10	
2-D	855-937-7705	A082 EYESHIELD: SCD614697 (80063)	2	EA	1									1A3A1A1	
1-D		A083 BODY: SCD614697-2 (80063)	2	EA	1									1A3A1A1MP1	
1-D		A084 LEAF: SCD614697-3 (80063)	2	EA	2									1A3A1A1MP2	
1-D		A085 LEAF: SAME AS A084	2	EA	REF									1A3A1A1MP3	
-D		A086 ADHESIVE-SEALANT, SILICONE RBR: 2 RTV118 (01139)	2	TU	V						*	*		1A3A1A1MP4	
2-D	310-914-8236	A087 RETAINER, NUT: SCC614624 (80063)	2	EA	1									1A3A1MP1	
-D	040-142-9823	A088 ADHESIVE-SEALANT, SILICONE RBR: 2 RTV109 (01139)	2	TU	V						*	*		1A3A1MP3	
-D	855-167-7885	A089 HOUSING, LENS CELL EYEPiece: SCD635092-1 (80063)	1,2	EA	1				*	*	*	*	*	8 7	
-D	330-777-6348	A090 PACKING, PREPMD: MS29513-031 (96906)	1,2	EA	1				*	*	*	*	*	8 8	
-D	855-167-7886	A091 CELL, LENS: SCD635100 (80063)	1,2	EA	1				*	*	*	*	*	8 3	
-D	855-167-7887	A092 LENS, DOUBLET: SCC635109-1 (80063)	1,2	EA	1				*	*	*	*	*	8 17	
-D	855-167-7896	A093 SPACER: SCC635083 (80063)	1,2	EA	1				*	*	*	*	*	8 16	
-D	855-167-7888	A094 LENS, TRIPLET: SCC635108-1 (80063)	1,2	EA	1				*	*	*	*	*	8 15	
-D	855-167-7895	A095 SPACER: SCC635091 (80063)	1,2	EA	1				*	*	*	*	*	8 14	
-D	855-167-7890	A096 LENS, OPT ELEM: SCC635102-1 (80063)	1,2	EA	1				*	*	*	*	*	8 13	
-D	330-579-9833	A097 PACKING, PREPMD: MS28775-025 (96906)	1,2	EA	1				*	*	*	*	*	8 12	
-D	855-069-3107	A098 ADAPTER RING, RETAINER ASSEMBLY: SCC615716 (80063)	1,2	EA	1				*	*	*	*	*	8 11	
-D	855-167-7891	A099 POINTER: SCB635097 (80063)	1,2	EA	1				*	*	*	*	*	8 4	
-D	855-167-7892	A100 RING, FOCUSING: SCD635090 (80063)	1,2	EA	1				*	*	*	*	*	8 1	
-D	305-928-7088	A101 SCREW, SELF-LOCKING PANHEAD: NAS1190C04F4N (80205)	1,2	EA	3				*	*	*	*	*	8 2	
-F	855-245-8445	A102 ADAPTER PLATE, EYEPiece CELL: SCD635167 (80063)	1,2	EA	1				*	*	*	*	*	4 11	
-F	305-960-7458	A103 SCREW, MODIFIED: SCB635130 (80063)	1,2	EA	4				*	*	*	*	*	4 7	
-D	030-878-9520	A104 SEALING CMPD: MILS11030TYPE1CLASS1 (81349)	1,2	CN	V						*	*		1A3MP16	
-D	850-295-7685	A105 SILICONE CMPD: SAME AS A079	1,2	CN	V						*	*		1A3MP17	
-D		A106 SEALING CMPD: SAME AS A032	1,2	CN	V						*	*		1A3MP18	
-F	855-245-8442	A107 SPACER EYEPiece: SCC635174 (80063)	1,2	EA	1				*	*	*	*	*	4 12	

SECTION II REPAIR PARTS FOR DIRECT SUPPORT, GENERAL SUPPORT, AND DEPOT MAINTENANCE (CONTINUED)

(1) SHR CODE	(2) FEDERAL STOCK NUMBER	(3) DESCRIPTION REFERENCE NUMBER & MFR. CODE	USABLE ON CODE	(4) UNIT OF MEAS	(5) QTY & IN KIT	(6) 30-DAY DS MAINT ALLOWANCE			(7) 30-DAY GS II ALLOWANCE			(8) I YI W PE EQUI NTGC	(9) EPOT AJNT WPER 100 DU1P	(10) ILLUSTRATIONS	
						(a) -20	(b) 1-54	(c) -14	(a) -20	(b) 1-54	(c) -10			(a) FIG NO.	(b) ITEM NO. OR REFERENCE DESIGNATION
-D	5305-143-1834	A108 SCREW, GUIDE: SCB635098 (80063)	1, 2	EA	1						*	*	8	5	
-D	5305-143-1835	A109 SCREW: SCB635126 (80063)	1, 2	EA	1						*	*	8	9	
-O-S	5855-433-2350	A110 MOUNT ASSEMBLY, BORESIGHT: SCD635170-2 (80063)	2	EA	1				*	*	*	*	3	6	
-O-S	5855-245-8446	A110A MOUNT ASSEMBLY, BORESIGHT: SC-D-63517 0-1 (80063)	1	EA	1				*	*	*	*	3	6	
-F	5855-409-8150	A111 FRAME, BR51T MOUNT ASSY: SCD635168 (80063)	1, 2	EA	1				*	*	*	*	5	1A4A1	
1-F		A112 FRAME: SCD635168-2 (80063)	1, 2	EA	1								5	9	
1-D		A113 INSERT, SCR THD: SCB635173 (80063)	1, 2	EA	2									1A4A1MP2	
1-D	5340	A114 INSERT, SCR THD: SAME AS A113	1, 2	EA	1EF									1A4MP3	
1-D		A115 PIN: SCB635171 (80063)	1, 2	EA	2									1A4A1MP4	
1-D		A116 PIN: SAME AS A115	1, 2	EA	1EF									1A4A1MP5	
1-D		A117 BEARING, SLEEVE: MS17795 -22 (96906)	1, 2	EA	1									1A4A1MP6	
-F	5305-087-3087	A118 SCREW, LOCKING: SCB614662 (80063)	1, 2	EA	2				*	*	*	*	5	1	
-F	5305-087-3087	A119 SCREW, LOCKING: SAME AS A118	1, 2	EA	1EF				*	*	*	*		1A4H2	
-F	5355-087-2770	A120 KNOB, LOCKING: SCC614661 (80063)	1, 2	EA	2				*	*	*	*	5	2	
-F	5355-087-2770	A121 KNOB, LOCKING: SAME AS A120	1, 2	EA	1EF				*	*	*	*		1A4H4	
-F	5315	A122 PIN, GROVED HEADLESS: SCB635155 (80063)	1, 2	EA	1				*	*	*	*	5	3	
-F	5360-433-2415	A123 SPRING, SPIRAL, TORSION: SCB635172 (80063)	1, 2	EA	1				*	*	*	*	5	5	
-F	5305-448-4673	A124 SCREW, CAPTIVE BORESIGHT MOUNT: SCB635157-1 (80063)	1, 2	EA	1				*	*	*	*	3	1	
-F	5305-448-4674	A125 SCREW, CAPTIVE BORESIGHT MOUNT: SCB635157-2 (80063)	2	EA	1				*	*	*	*	5	8	
-F	5855-409-8151	A126 PIN, BORESIGHT MOUNT: SCB635165 (80063)	1, 2	EA	1				*	*	*	*	5	10	
-F	5855-409-8149	A127 SHAFT, BR51T MT: SCB635158 (80063)	1, 2	EA	1				*	*	*	*	5	11	
-F	5310-087-3057	A128 WASHER: SCB614660 (80063)	1, 2	EA	2				*	*	*	*	5	12	
-F	5310-087-3057	A129 WASHER: SAME AS A128	1, 2	EA	1EF				*	*	*	*		1A4H10	
-F	5355-409-8116	A130 KNOB, BORESIGHT MOUNT: SCC635177 (80063)	1, 2	EA	2				*	*	*	*	5	13	
-F	5355-409-8116	A131 KNOB, BORESIGHT MOUNT: SAME AS A130	1, 2	EA	1EF				*	*	*	*		1A4H12	
-F	5855-409-8148	A132 SCREW, BR51T MT: SCB635159 (80063)	1, 2	EA	1				*	*	*	*	5	14	
-F	5855-409-8152	A133 POST, BORESIGHT MOUNT: SCB635160 (80063)	1, 2	EA	1				*	*	*	*	5	15	
-F	5360-433-2416	A134 SPRING, HELICAL CPRSN: SCB635166 (80063)	1, 2	EA	2				*	*	*	*	5	16	
-F	5360-433-2416	A135 SPRING, HELICAL CPRSN: SAME AS A134	1, 2	EA	1EF				*	*	*	*		1A4MP5	

SECTION II REPAIR PARTS FOR DIRECT SUPPORT, GENERAL SUPPORT, AND DEPOT MAINTENANCE (CONTINUED)

(1) SMR CODE	(2) FEDERAL STOCK NUMBER	(3) DESCRIPTION REFERENCE NUMBER & MFR. CODE	USABLE ON CODE	(4) UNIT OF MEAS	(5) QTY NC II UNIT	30-DAY DS MAINT ALLOWANCE			(7)			(8) 1 YR W PE QU II ITGC1	(9) EPO AINT W PE QU IIP	(10) ILLUSTRATIONS	
						(a) -20	(b) -50	(c) -10	(a) -20	(b) -50	(c) -10			(a) FIG NO.	(b) ITEM NO. OR REFERENCE DESIGNATION
P-F	531 0-42 0-0610	A136 WASHER, THRUST, BORESIGHT MOUNT SCB635161 (80063)	1,2	EA	1	*	*	*	*	*	*	*	5	18	
P-F	5365-419-4627	A137 RING, RTMG: SCB635162 -18 (80063)	1,2	EA	1	*	*	*	*	*	*	*	5	19	
P-F	5365-415-9272	A138 RING, RTMG: SCB635162 -25 (80063)	1,2	EA	1	*	*	*	*	*	*	*	5	20	
P-F	5315-844-5644	A139 P IN-SPRING: MSL71436 (96906)	1,2	EA	2	*	*	*	*	*	*	*	5	21	
P-F	5315-844-5644	A140 P IN-SPRING: SAME AS A139	1,2	EA	REF	*	*	*	*	*	*	*		1A4H16	
P-F	5315-807-7957	A141 P IN-SPRING: MS16555 -608 (96906)	1,2	EA	1	*	*	*	*	*	*	*	5	22	
P-F	3110-294-2614	A142 BEARING, BALL: MS9461 -05 (96906)	1,2	EA	1	*	*	*	*	*	*	*	5	23	
P-F	3110-131-7071	A143 BEARING, BALL: MS9461 -03 (96906)	1,2	EA	2	*	*	*	*	*	*	*	5	24	
P-F	3110-131-7071	A144 BEARING, BALL: SAME AS A143	1,2	EA	REF	*	*	*	*	*	*	*		1A4MP10	
P-F	5305	A145 SCREW, SELF-LOCKING, TRUSS HD: SCB635163 (80063)	1,2	EA	1	*	*	*	*	*	*	*	5	25	
P-F	9150-754-2595	A146 GREASE, MOLYBDENUM DISULFIDE: MILG21164 (81349)	1,2	CN	V	*	*	*	*	*	*	*		1A4MP11	
P-F	5855-433-2351	A147 CROSS BAR, BRST MOUNT: SCD635164-2 (80063)	2	EA	1	*	*	*	*	*	*	*	5	27	
P-F		A147A CROSSBAR, BORESIGHT MOUNT: SC-D-635164-1 (80063)	1	EA	1	*	*	*	*	*	*	*	5	26	
P-F	5360-415-2229	A148 SPRING, FLAT: SCB635154 (80063)	2	EA	1	*	*	*	*	*	*	*	5	29	
X-F		A148A STRAP, BORESIGHT MOUNT: SC-C-635144 (80063)	1	EA	1								5	4	
X-F		A148B SCREW, CAPTIVE, BORESIGHT MOUNT: SC-B-635156 (80063)	1	EA	1								5	6	
X-F		A148C SPRING, FLAT: SC-C-635175 (80063)	1	EA	1								5	28	
X-F		A148D ADAPTER, BORESIGHT MOUNT: SC-C-635169 (80063)	1	EA	1								5	17	
P-O	5855-245-8444	A149 CAP, COVER ASSY: SCD635148 (80063)	1,2	EA	1	*	*	*	*	*	*	*	4	27	
X1-D		A150 CAP, COVER: SCD635148-2 (80063)	1,2	EA	1									1A5MP1	
X1-D		A151 GLASS: SCD635148-3 (80063)	1,2	EA	1									1A5MP2	
P-F	5330-935-9238	A152 PACKING, PREEMD: SCB635059-1 (80063)	1,2	EA	1	*	*	*	*	*	*	*	4	17	
P-F	5330-935-9239	A153 PACKING, PREEMD: SCB635059-3 (80063)	1,2	EA	1	*	*	*	*	*	*	*	4	25	
P-F	5305-682-8046	A154 SCREW, MODIFIED SOCKET HEAD: SCB635133-7 (80063)	1,2	EA	4	*	*	*	*	*	*	*	4	29	
P-F	5305-682-8046	A155 SCREW, MODIFIED SOCKET HEAD: SAME AS A154	1,2	EA	REF	*	*	*	*	*	*	*		1MP4	
P-F	5305-682-8046	A156 SCREW, MODIFIED SOCKET HEAD: SAME AS A154	1,2	EA	REF	*	*	*	*	*	*	*		1MP5	
P-F	5305-682-8046	A157 SCREW, MODIFIED SOCKET HEAD: SAME AS A154	1,2	EA	REF	*	*	*	*	*	*	*		1MP6	
P-F		A158 SCREW, MODIFIED SOCKET HEAD: SCB635133-33 (80063)	1,2	EA	2	*	*	*	*	*	*	*	3	7	
P-F		A159 SCREW, MODIFIED SOCKET HEAD: SAME AS A158	1,2	EA	REF	*	*	*	*	*	*	*		1MP8	

SECTION II REPAIR PARTS FOR DIRECT SUPPORT, GENERAL SUPPORT, AND DEPOT MAINTENANCE (CONTINUED)

(1) SFR CODE	(2) FEDERAL STOCK NUMBER	(3) DESCRIPTION REFERENCE NUMBER & MFR. CODE		(4) UNIT OF MEAS	(5) QTY INC IN UNIT	(6) 30-DAY DS MAINT ALLOWANCE			(7) 30-DAY GS MAINT ALLOWANCE			(8) 1 YR ALW PER EQUIP CNTGCTY	(9) DEPOT MAINT ALW PER 100 EQUIP	(10) ILLUSTRATIONS		
						USABLE ON CODE	(a) 1-20	(b) 21-50	(c) 51-100	(a) 1-20	(b) 21-50			(c) 51-100	(a) FIG NO.	(b) ITEM NO. OR REFERENCE DESIGNATION
M-D		A160	PLATE,IDENT: SCC635178 (80063)	1,2	EA	1								3	10	
P-F	6850-295-7685	A161	SILICONE COMPD: SAME AS A079	1,2	CN	V			*	*	*	*	*		1MP10	
P-O-S	5855-134-6257	A162	RECEIVER MOUNT AS SEMBLY, M-14: 1,2 SCC635152 (80063)	1,2	EA	1			*	*	*	*	*	13	2	
X1-O		A163	MOUNT,RECEIVER: SCD635147 (80063)	1,2	EA	1								13	1	
X1-F		A164	MOUNT, RECEIVER: SCD635147-2 (80063)	1,2	EA	1									2A1MP1	
X1-F		A165	PIN, STR, HDLS: SCD635147-3 (80063)	1,2	EA	1								13	2	
P-F	5310-087-3055	A166	WASHER,LOCK: SCB645752 -158 (80063)	1,2	EA	1			*	*	*	*	*	13	3	
P-F	5305	A167	SCREW,CAP,SOC HD: SCC607134 (80063)	1,2	EA	1			*	*	*	*	*	13	4	
P-O-S	5855-134-6258	A168	RECEIVER MOUNT ASSEMBLY, M-16 : 1,2 SCC635145 (80063)	1,2	EA	1			*	*	*	*	*	14	3	
X1-O		A169	BRACKET, M-16 : SCC635149 (80063)	1,2	EA	1								14	6	
P-F	5855-087-1565	A170	TAB: SCC607232 (80063)	1,2	EA	1			*	*	*	*	*	14	5	
P-F	5310-087-3055	A171	WASHER, LOCK: SAME AS A166	1,2	EA	1			*	*	*	*	*	14	2	
P-F	5310-087-3099	A172	NUT, WING, PL: SCB607255 (80063)	1,2	EA	1			*	*	*	*	*	14	1	
P-F	5305-087-3080	A173	SCREW, HEX HD MACHINE: SCB645759 -312 (80063)	1,2	EA	1			*	*	*	*	*	14	4	
P-F	5310	A174	WASHER,FLAT: SCB645751-809 (80063)	1,2	EA	1			*	*	*	*	*	14	3	
P-O	6135-056-7612	A175	BATTERY TRAY ASSEMBLY: MILB18BA1533 (81349)	1,2	EA	3			*	*	*	*	*	6	4	
P2-O-S	5855-245-8443	A176	CARRYING CASE: SCD635146 (80063)	1,1	EA	1			*	*	*	*	*	1	5	
X1-O	5855	A177	BODY: SCD635146-1 (80063)	1,2	EA	1								1	11	
X1-F		A178	CAP: SCD635146-2 (80063)	1,2	EA	1								1	10	
P-F	5330-437-7314	A179	SEAL: SCC635176 (80063)	1,2	EA	1			*	*	*	*	*		5MP3	
X1-O		A180	CAP RETAINER: SCB635151 (80063)	1,2	EA	1									5MP4	
X2-O	5320-582-3305	A181	RIVET: MS20600AD4W3 (96906)	1,2	EA	5									5H1	
X1-F		A182	CUSHION, TOP: SCD635153-1 (80063)	1,2	EA	1									5MP5	
X1-F		A183	CUSHION, BOTTOM: SCD635153-2 (80063)	1,2	EA	1									5MP6	
X1-F		A184	BUCKLE: MILB543TYPE3STYLE3CLASS3 (81349)	1,2	EA	1									5MP7	
X2-F	5340-078-7029	A185	CLIP, END, STRAP: MILC496 (81349)	1,2	EA	1									5MP12	
X-F		A186	KEEPER, WITH SLIDE: MILH9890TYPEX (81349)	2	EA	2									5MP8	
X-F		A187	KEEPER, WITH SLIDE: SAME AS A186	2	EA	REF									5MP9	

SECTION II REPAIR PARTS FOR DIRECT SUPPORT, GENERAL SUPPORT, AND DEPOT MAINTENANCE (CONTINUED)

(1) SMR CODE	(2) FEDERAL STOCK NUMBER	DESCRIPTION REFERENCE NUMBER & MFR. CODE	USABLE ON CODE	UNIT OF MEAS	(5) QTY REQ UNIT	(6)			(7)			(8) I YR W PEI QU I F ITOCY	(9) EPOI AINT W PE 100 201P	(10) ILLUSTRATIONS	
						30-	Y DS LOW	INT	30-	GS MAU	INT			(a)	(b)
						(a) -20	(b) 1-51	(c) -10	(a) -20	(b) 1-50	(c) 1-10			(a) FIG NO.	(b) ITEM NO. OR REFERENCE DESIGNATION
X-F		A188 WEBBING AND TAPE ,TEXTILE : MILW530TYPE2A (81349)	2	EA	1										5MP10
X-F		A189 WEBBING AND TAPE ,TEXTILE : MILW530TYPE (81349)	2	EA	1										5MP11
X2-F	5320-582-3268	A190 RIVET : MS20600AD6W3 (96906)	2	EA	3										5MP12
P-F		A191 ADHESIVE : MILA25457 (81349)	2	CN	1				*	*	*	*	*		5MP13
P-F-T	5855-054-8490	A192 IMAGE INTENSIFIER ASSY, 18MM : 1,2 SCD646776 (80063)	1,2	EA	1				*	*	*	*	*	4	13
P-F	5340-880-7831	A193 CAP ,PROTECTIVE : SCB611742 (80063)	2	EA	2				*	*	*	*	*		6MP1
P-F	5340-880-7831	A194 CAP , PROTECTIVE : SAME AS A193	2	EA	REF				*	*	*	*	*		6MP2
P-D		A195 CONTACT , ELEC : SCC646782 (80063)	2	EA	2						*	*	*	4	14
P-D		A196 CONTACT ,ELEC : SAME AS A195	2	EA	REF						*	*	*	4	16
X-F		A197 CUSHION, SHIPPING AND STORAGE : 2 SCD646781 (80063)	2	EA	2										6MP5
X-F		A198 CUSHION , SHIPPING AND STORAGE : 2 SAME AS A197	2	EA	REF										6MP6
P-D		A199 HOUSING ASSY. IMAGE INTENSIFIER: 2 SCD646777 (80063)	2	EA	1						*	*	*		6A1
X1-D		A200 HOUSING, IMAGE INTENSIFIER: SCD646783 (80063)	2	EA	1										6A1MP1
X-D		A201 PRIMER, SILICONE RUBBER: 1201 (71984)	2	CN	1										6A1MP2
X1-D		A202 RETICLE , OPT ICAL INSTRUMENT : SCD646784 (80063)	2	EA	1										6A1MP3
X-D		A203 SEALANT: 93033 (71984)	2	CN	1										6A1MP4
P-D	5855-476-6659	A204 PLATE ,RETAINING , WINDOW: SCC646779 (80063)	2	EA	1						*	*	*		6MP7
P-D	5855-432-2327	A205 RETA INER , OPT ICAL ELEMENT : SCD646780 (80063)	2	EA	1						*	*	*		6MP8
P-D		A206 SCREW, NYLON ,FLAT HEAD : MS18211-3C (96906)	2	EA	1						*	*	*		6MP9
X1-D		A207 TUBE ASSY, IMAGE INTENSIFIER: SCD646778 (80063)	2	EA	1										6A2
P-D	5935-431-3609	A208 BRACKET ASSY , ELECTRICAL CONNE : SCC646790 (80063)	2	EA	1						*	*	*		6A2MP1
P-D	585 5-427-7784	A209 HIGH VOLTAGE MULTIPLIER : SCD646789 (80063)	2	EA	1						*	*	*		6A2VM1
P-D	5855-427-7778	A210 HOLDER, MODULE: SCD646787 (80063)	2	EA	2						*	*	*		6A2MP2
P-D	5855-427-7778	A211 HOLDER, MODULE: SAME AS A210	2	EA	REF						*	*	*		6A2MP3
P-D	5855-055-1307	A212 MODULE , IMAGE INTENSIFIER: SCD646786-1 (80063)	2	EA	1						*	*	*		6A2V1
P-D	5855-057-6900	A213 MODULE , IMAGE INTENSIFIER : SCD646786-2 (80063)	2	EA	1						*	*	*		6A2V2
P-D	5855-168-7891	A214 MODULE , IMAGE INTENSIFIER : SCD646786-3 (80063)	2	EA	1						*	*	*		6A2V3
P-D	5855-427-7775	A215 OSC ILLATOR ASSY : SCD646788 (80063)	2	EA	1						*	*	*		6A2Y1
X-D		A216 PRIMER, SILICONE: SCC634290-1 (80063)	2	CN	1										6A2MP4

SECTION II REPAIR PARTS FOR DIRECTSUPPORT, GENERAL SUPPORT, AND DEPOT MAINTENANCE (CONTINUED)

(1) SMF CODE	(2) FEDERAL STOCK NUMBER	(3) DESCRIPTION REFERENCE NUMBER & MFR. CODE		(4) UNIT OF MEAS	(5) QTY REQ INIT	(6) YDS ALLOWANCE			(7) GTS INT			(8) I Y LWPI EQUI WTGC	(9) EPO AIN WPI 100 2011	(10) ILLUSTRATIONS		
						(a) -2	(b) -5	(c) -1	(a) -2	(b) -5	(c) -1			(a) -2	(b) -5	(c) -1
-D	1970-689-883	1217	SILICONE RUBBER: SCC599350 (80063)	2	GL	1						*	*			6A2MP5
-O	1640-597-674	1218	PAPER, LENS: NNMP40TYPE1SIZE4 (81348)	1,2	EA	1			*	*	*	*	*	1	6	
-O	1120-198-539	1219	KEY, SOCKET HD SCREW: GGGK275TYPE1CLASS1 (81348)	1,2	EA	1			*	*	*	*	*	1	3	
-F	1310-935-909	1220	WASHER, SPRING TENSION: SCC635129 (80063)	1,2	EA	1			*	*	*	*	*			MP4

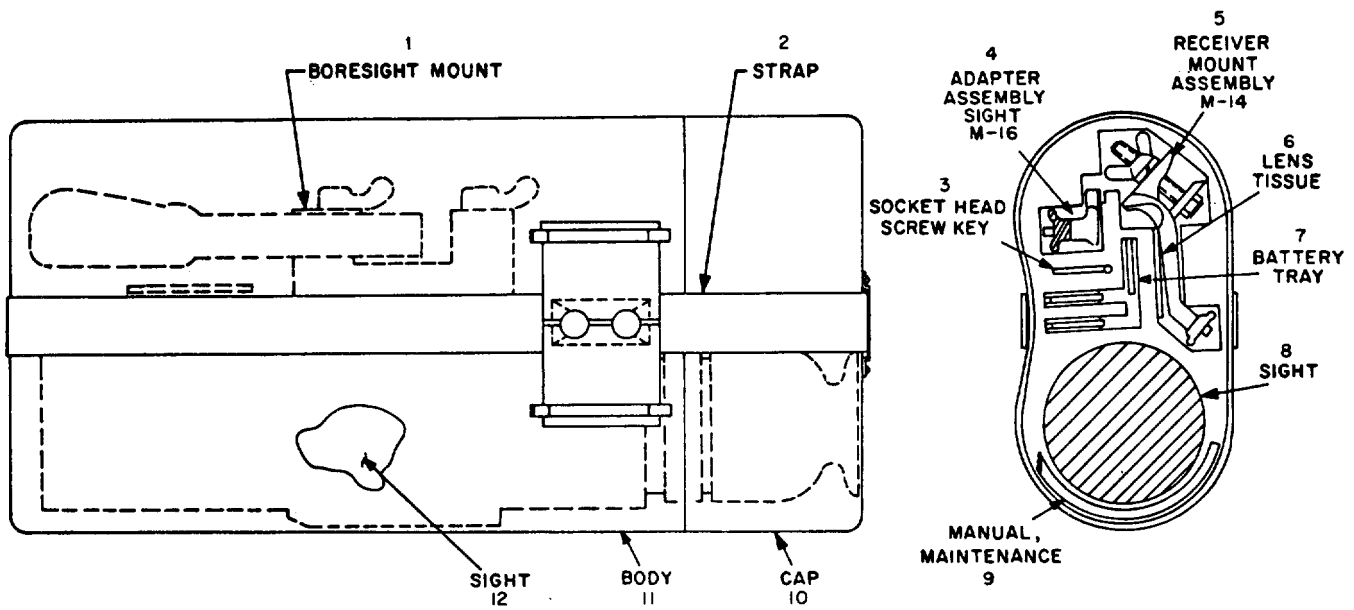

SC-D-635150-1 AND -2

EL5855-209-40P-TM-1

Figure 1. Carrying case, sight, and accessories.

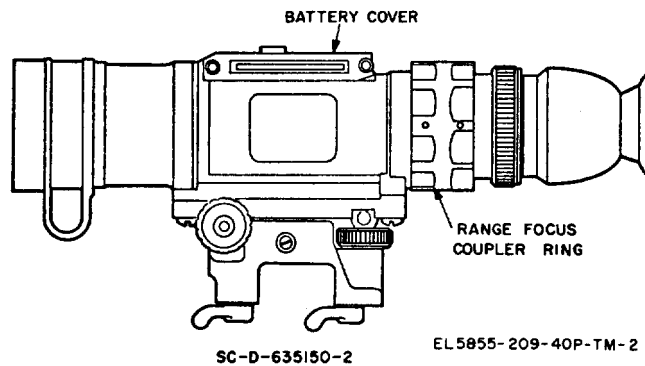
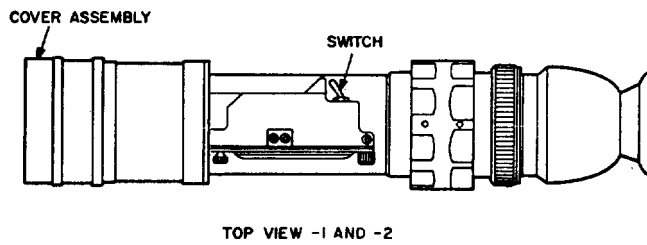
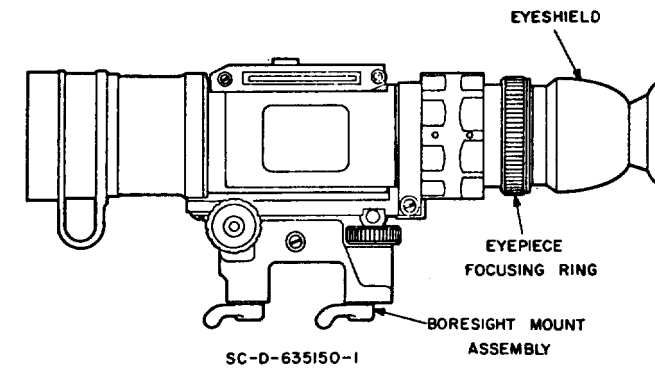
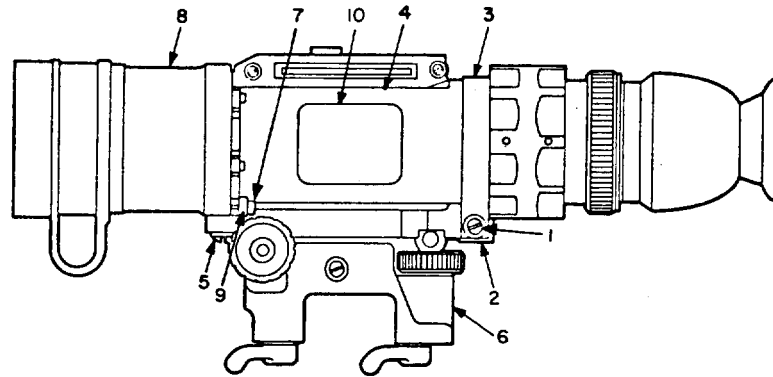
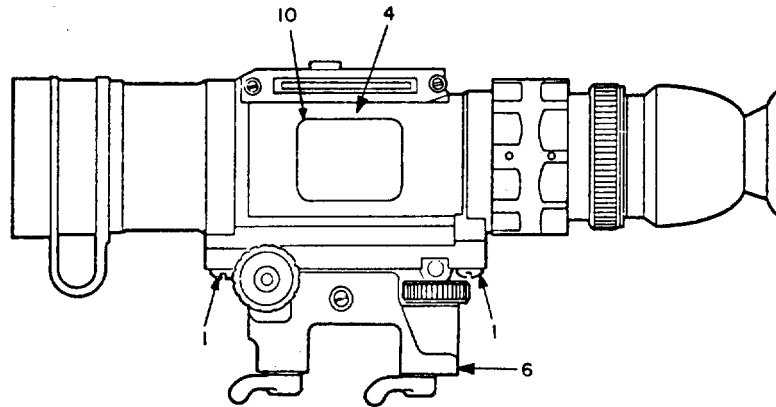

Figure 2. Night Vision Sights, Miniaturized AN/PVS-3 and AN/PVS-3A.



SC-D-635150-1



SC-D-635150-2

LEGEND

- | | |
|----------------------------------|-------------------------------|
| 1. Boresight mount captive screw | 6. Boresight mount assembly |
| 2. Flat spring | 7. Modified socket head screw |
| 3. Boresight mount strap | 8. Objective lens assembly |
| 4. Body assembly | 9. Boresight mount adapter |
| 5. Boresight mount captive screw | 10. Identification plate |

EL5855-209-40P-TM-3

Figure 3. Boresight assembly removal.

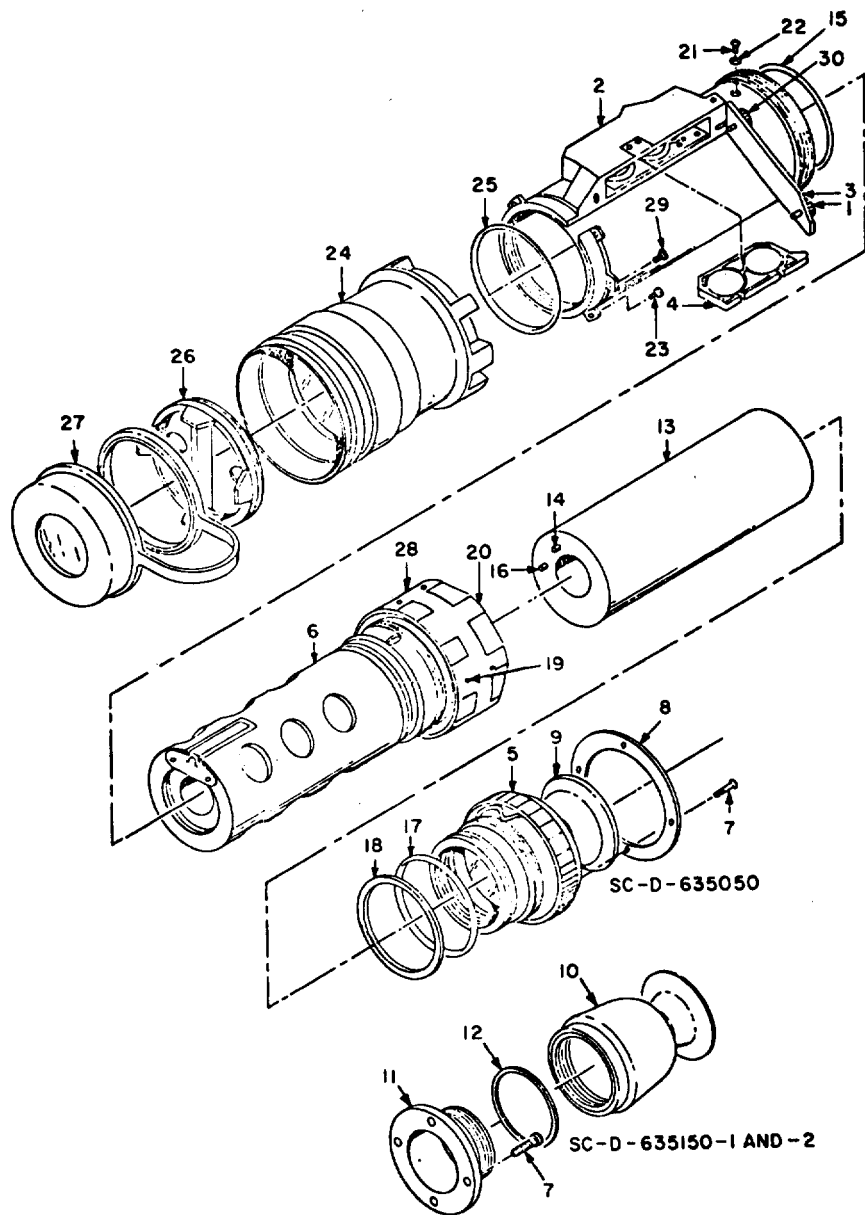

EL5855-209-40P-TM-4

- | | |
|---|---|
| <p>1 Screw
 2 Body assembly (1A2)
 3 Cover assembly
 4 Battery tray assembly (4)
 5 Eyepiece assembly (1A3)
 6 Tube focus assembly (1A2A2)
 7 Screw, remodified (1A3H4)
 8 Retaining rings
 9 Eye shield
 10 Eyeshield assembly (1A3A1)
 11 Adapter plate, eyepiece cell (1A3MP15)
 12 Spacer, eyepiece (1A3MP19)
 13 Image intensifier assembly, 18-mm (6)
 14 Contact, electrical (6MP3)
 15 Packing, preformed (1A2MP2)
 16 Contact, electrical (6MP4)</p> | <p>17 Packing, preformed (IMP1)
 18 Spring washer
 19 Setscrew (1A2H2)
 20 Coupler ring
 21 Screw, guide (1A2H1)
 22 O-ring
 23 Screw, modified socket head (IMP7)
 24 Objective lens (1A1)
 25 Packing, preformed (IMP2)
 26 Attenuator assembly (SC-D-635050 only)
 27 Cap, cover assembly (1A5) (SC-D-35150-1 and SC-D-6351-2)
 28 Setscrew (1A2H6)
 29 Screw, modified socket head (IMP3)
 30 Screw, shoulder (1A2A1H2)</p> |
|---|---|

Dispose of according to instructions after completion of MWO 11-5855-209-30/1.

Figure 4. Night Vision Sights Miniaturized AN/PVS-3.

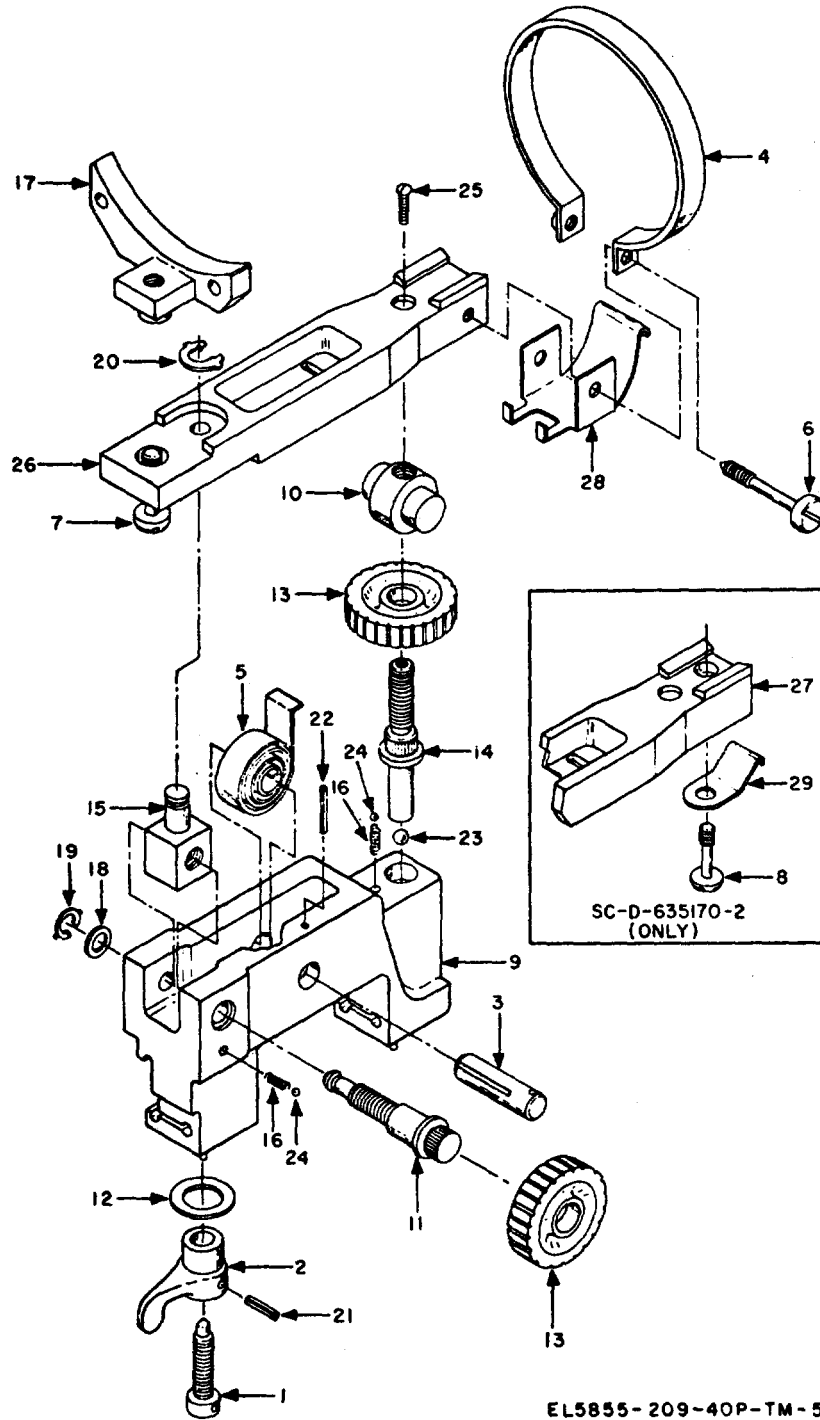

EL5855-209-40P-TM-5

- | | |
|--|---|
| 1 Screw, locking (1A4H1) | 16 Spring, helical compression (1A4MP4) |
| 2 Knob, locking (1A4H3) | 17 Adapter, boresight mount |
| 3 Pin (1A4H5) | 18 Washer, thrust, boresight mount (1A4H1) |
| 4 Strap (-1) | 19 Ring, retaining (1A4MP6) |
| 5 Spring, spiral, torsion (1A4MP1) | 20 Ring, retaining (1A4MP7) |
| 6 Strap, boresight mount | 21 Pin-spring (1A4H15) |
| 7 Screw, captive boresight mount (1A4H6) | 22 Pin-spring (1A4H17) |
| 8 Screw, captive boresight mount (1A4H7) | 23 Bearing, ball (1A4MP8) |
| 9 Frame (1A4A1MP1) | 24 Bearing, ball (1AMP9) |
| 10 Pin, boresight mount (1A4H8) | 25 Screw, self-locking, truss head (1A4H18) |
| 11 Shaft, boresight mount (1A4MP2) | 26 Crossbar, boresight mount |
| 12 Washer (1A4H9) | 27 Crossbar, boresight mount (1A4MP12) |
| 13 Knob, boresight mount (1A4H11) | 28 Spring, flat |
| 14 Screw, boresight mount (1A4H13) | 29 Spring, flat (1A4MP13) |
| 15 Past, boresight mount (1A4MP3) | |

Figure 5. Boresight assembly.

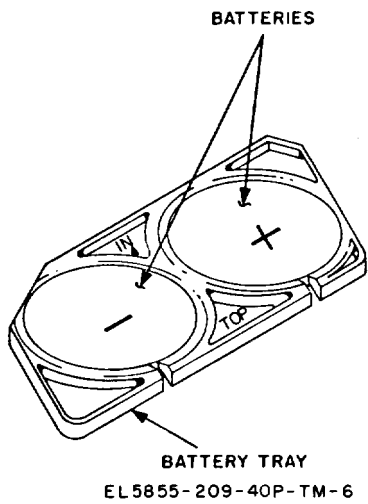

Figure 6. Battery tray assembly.

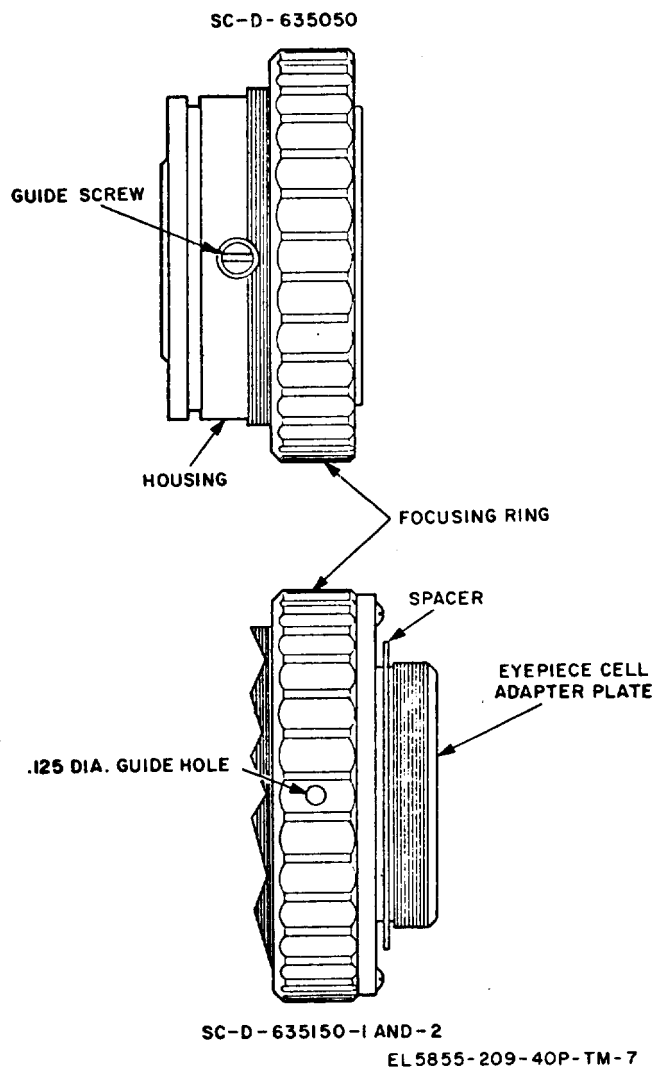
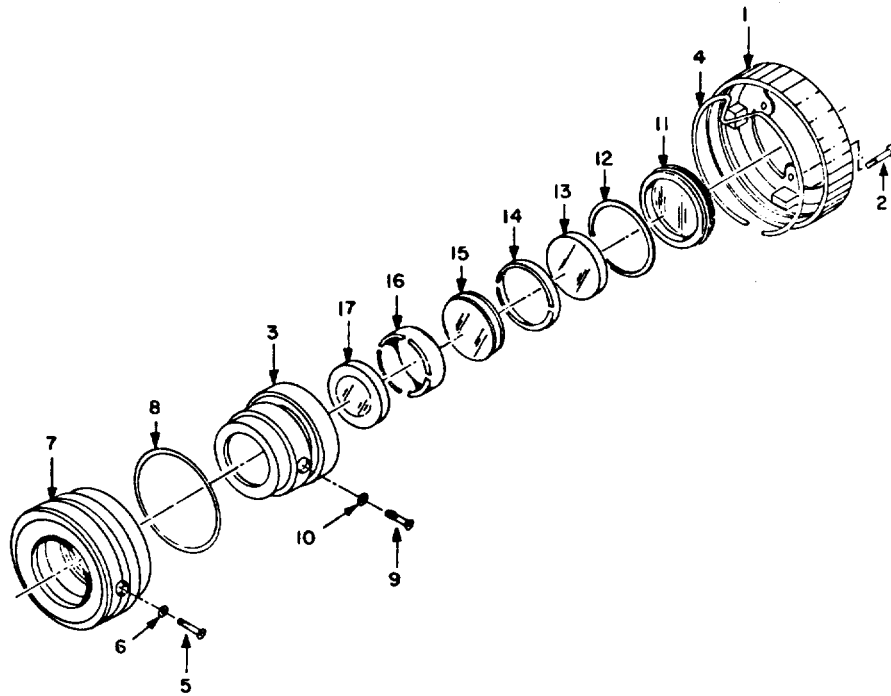

Figure 7. Eyepiece assembly.



- LEGEND**
- | | |
|-----------------------|----------------------------------|
| 1. FOCUSING RING | 9. SCREW |
| 2. SCREW | 10. O-RING |
| 3. LENS CELL | 11. ADAPTER RING, RETAINER ASSY. |
| 4. POINTER | 12. PACKING, PREFORMED |
| 5. GUIDE SCREW | 13. LENS, OPTICAL ELEMENT |
| 6. O-RING | 14. SPACER |
| 7. HOUSING | 15. TRIPLET LENS |
| 8. PACKING, PREFORMED | 16. SPACER |
| | 17. DOUBLET LENS |

EL5855-209-40P-TM-8

Figure 8. Eyepiece assembly, exploded view.

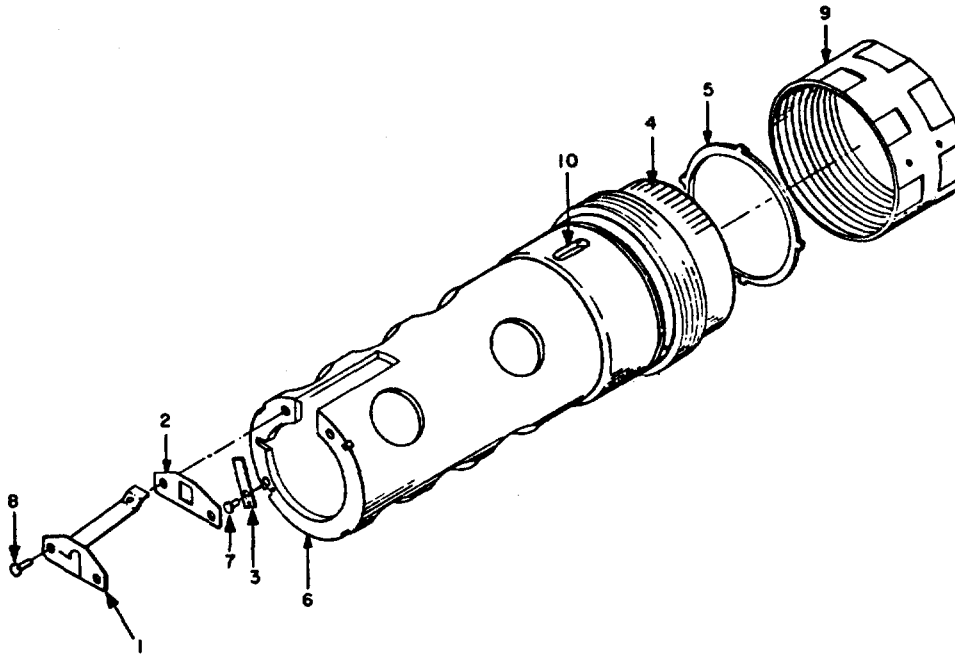

LEGEND

- 1. Electrical contact
- 2. Insulator
- 3. Ground contact
- 4. Diopter scale
- 5. Spacer, image intensifier tube
- 6. Focusing tube
- 7. Rivet, tubular
- 8. Rivet, insulet
- 9. Coupler ring
- 10. Drive slot

EL5855-209-40P-TM-9

Figure 9. Focusing tube assembly, exploded view.

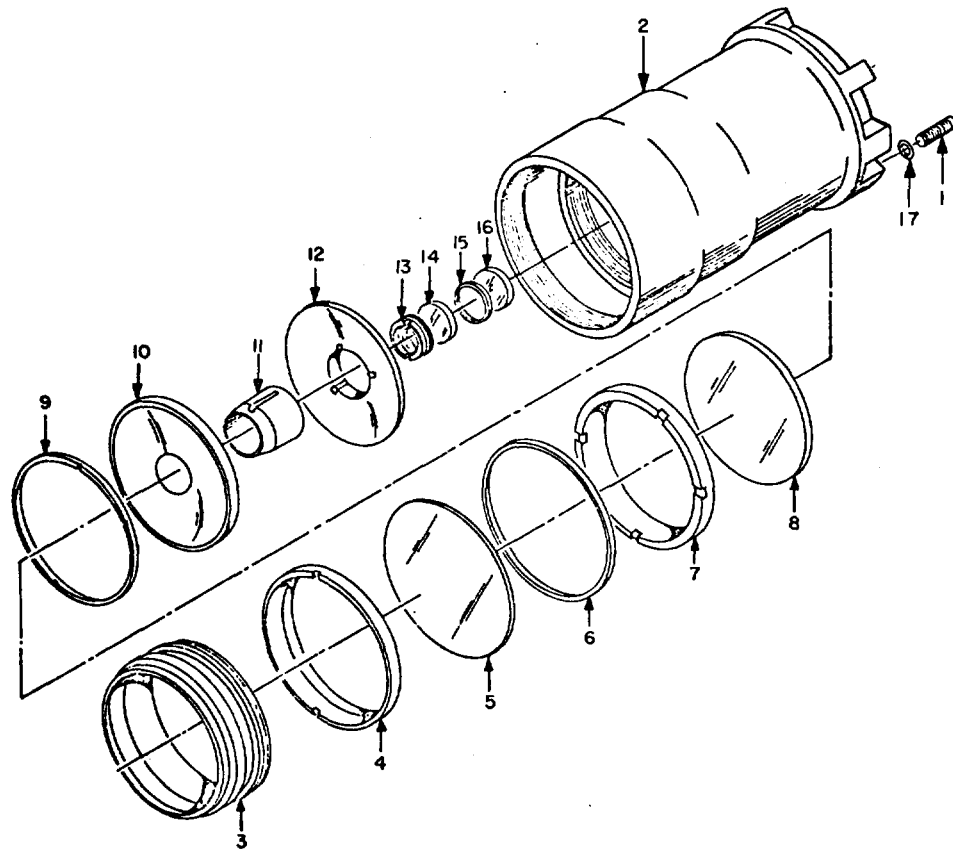

- LEGEND**
- | | |
|--------------------------|---------------------------|
| 1. SETSCREW | 9. SPACER, LENS |
| 2. HOUSING, OBJ LENS | 10. LENS, OPTICAL ELEMENT |
| 3. EXTERNAL SHADE | 11. MIRROR SHADE |
| 4. RETAINING RING | 12. PRIMARY MIRROR |
| 5. LENS, OPTICAL ELEMENT | 13. RETAINING RING |
| 6. PACKING, PREFORMED | 14. LENS, OPTICAL ELEMENT |
| 7. SPACER, LENS | 15. SPACER, LENS |
| 8. LENS, OPTICAL ELEMENT | 16. LENS, OPTICAL ELEMENT |
| | 17. PACKING, PREFORMED |

EL5855-209-40P-TM-10

Figure 10. Objective lens assembly, view 1.

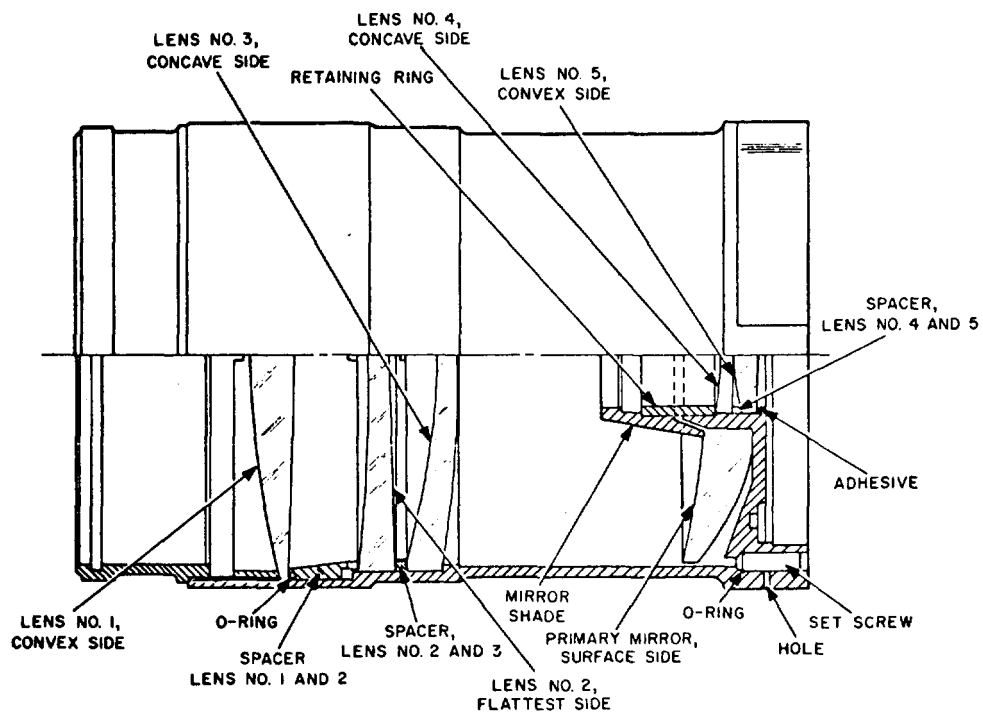

EL5855-209-40P-TM-11

Figure 11. Objective lens assembly, view 2.

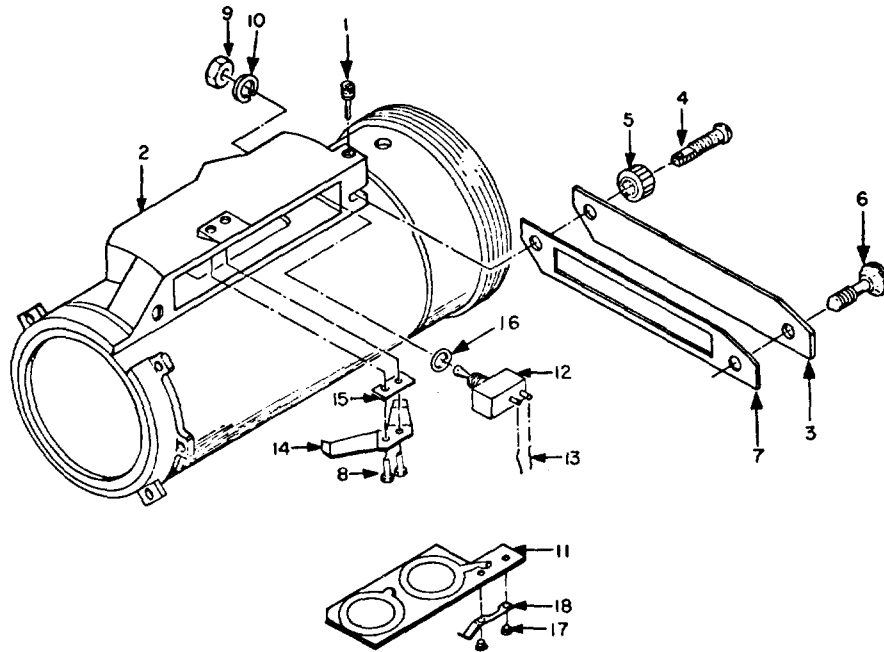

LEGEND:

- | | |
|------------------------|-------------------------|
| 1. SLOTTED PIN | 11. PC BOARD |
| 2. HOUSING SUBASSEMBLY | 12. SWITCH, TOGGLE |
| 3. BATTERY COVER | 13. WIRE |
| 4. SHOULDER SCREW | 14. CONTACT, ELECTRICAL |
| 5. KNURLED NUT | 15. INSULATOR, CONTACT |
| 6. SCREW | 16. O-RING |
| 7. GASKET | 17. EYELET, METALLIC |
| 8. INSULATED RIVET | 18. CONTACT, ELECTRICAL |
| 9. NUT | |
| 10. LOCKWASHER | |

EL5855-209-40P-TM-12

Figure 12. Housing assembly, exploded view.

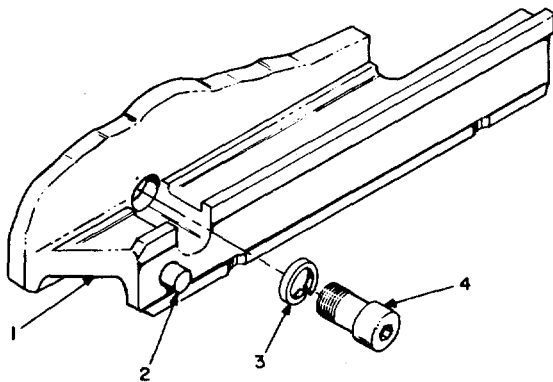

LEGEND:

- | |
|---------------------------|
| 1. MOUNT, RECEIVER M14 |
| 2. PIN, STRAIGHT HEADLESS |
| 3. WASHER, LOCK |
| 4. SCREW, CAP |

EL5855-209-40P-TM-13

Figure 13. Receiver Mount Assembly M14.

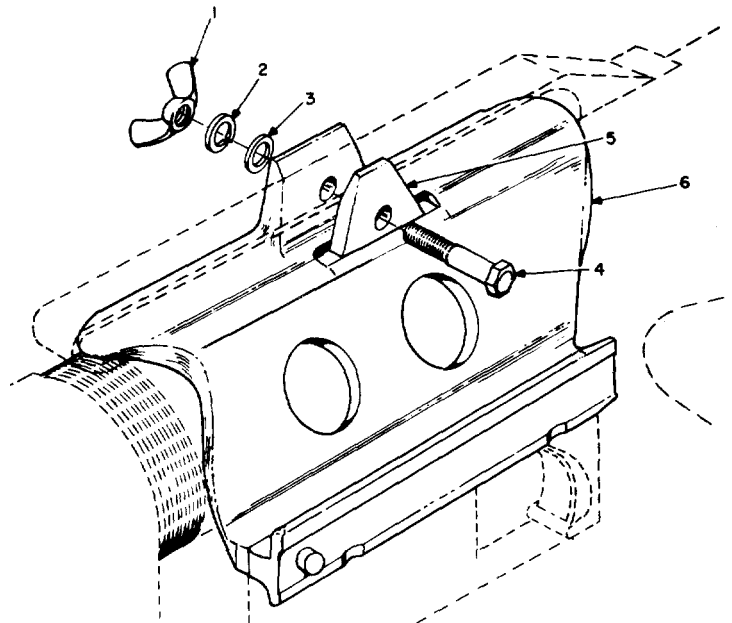

LEGEND:

- | | |
|-----------------|-------------------|
| 1. NUT, WING | 4. SCREW, MACHINE |
| 2. WASHER, LOCK | 5. TAB |
| 3. WASHER, FLAT | 6. BRACKET |

EL5855-209-40P-TM-14

Figure 14. Receiver Mount Assembly M16.

SECTION III INDEX-FEDERAL STOCK NUMBER CROSS REFERENCE

TO FIGURE AND ITEM NUMBER OR REFERENCE DESIGNATION

FEDERAL STOCK NUMBER	FIGURE NUMBER	ITEM NUMBER OR REF. DESIGNATION	FEDERAL STOCK NUMBER	FIGURE NUMBER	ITEM NUMBER OR REF. DESIGNATION
3110-131-7071		1A4MP10	5360-433-2416	5	16
3110-131-7071	5	24	5365-415-9272	5	20
3110-294-2614	5	23	5365-419-4627	5	19
5120-198-5392	1	3	5365-477-3894	10	15
5305-087-3080	14	4	5855-054-8490	4	13
5305-087-3087	5	1	5855-054-8503	4	6
5305-087-3087		1A4H2	5855-054-8540	3	8
5305-143-1834	8	5	5855-054-8618	12	1A2A1A1
5305-143-1835	8	9	5855-055-1307		6A2V1
5305-239-7858		1A2H3	5855-057-6900	8	6A2V2
5305-239-7858		1A2H4	5855-069-3107	11	11
5305-239-7858		1A2H5	5855-087-1565	14	5
5305-239-7858	4	19	5855-133-8772	4	21
5305-468-4673	3	1	5855-134-6257	13	2
5305-448-4674	5	8	5855-134-6258	14	3
5305-682-8046			5855-156-4993	2	2
5305-682-8046		1MP5	5855-167-7699	9	9
5305-682-8046		1MP6	5855-167-7700	12	2
5305-682-8046	4	29	5855-167-7702	12	14
5305-728-5496	10	1	5855-167-7706	9	5
5305-880-6895	4	30	5855-167-7885	8	7
5305-880-6896	4	1	5855-167-7886	8	3
5305-812-5788		1A2H7	5855-167-7887	8	17
5305-812-5788		1A2H8	5855-167-7888	8	15
5305-812-5788		1A2H9	5855-167-7890	8	13
5305-812-5788	4	28	5855-167-7891	8	4
5305-928-7088	8	2	5855-167-7892	8	1
5305-960-7458	4	7			
5310-087-3055	14	2	5855-167-7894	10	5
5310-087-3055	13	3	5855-167-7895	8	14
5310-087-3057		1A4H10	5855-167-7896	8	16
5310-087-3057	5	12	5855-167-7945	10	2
5310-087-3099	14	1	5855-167-7969	10	16
5310-420-0610	5	18	5855-167-7970	10	8
5310-880-9367	12	5	5855-167-7971	10	10
5310-914-8236		1A3A1MP1	5855-167-7972	10	14
5310-935-9097		MP4	5855-168-1497	10	12
5315-807-7957	5	22	5855-168-1498	10	4
5315-434-5759	5	3	5855-168-1499	10	13
5315-844-5644		1A4H16	5855-168-1500	10	3
5315-844-5644	5	21	5855-168-1501	10	7
5315-880-8975	12	1	5855-168-1503	10	9
5320-582-3268		5MP12	5855-168-1508	10	11
5320-582-3305		5H1	5855-168-7891		6A2V3
5320-792-3246	9	8	5855-245-8442	4	12
5330-134-3106	10	6	5855-245-8443	1	5
5330-437-7314		5MP3	5855-245-8444	4	27
5330-579-9833	8	12	5855-245-8445	4	11
5330-585-9772	10	17	5855-245-8446	3	6
5330-777-6348	8	8	5855-409-0920	4	5
5330-802-1360	4	15	5855-409-8148	5	14
5330-935-9238	4	17	5855-409-8149	5	11
5330-935-9239	4	15	5855-409-8150	5	1A4A1
5340-078-7029		5MP12	5855-409-8151	5	10
5340-443-5878		1A1A1MP2	5855-409-8152	5	15
5340-443-5878		1A1A1MP3	5855-427-7775		6A2Y1
5340-443-5878		1A1A1MP4	5855-427-7778		6A2MP2
5340-443-5878		1A1A1MP5	5855-427-7778		6A2MP3
5340-443-5878		1A1A1MP6	5855-427-7784		6A2VM1
5340-443-5878		1A1A1MP7	5855-432-2327		6MP8
5340-880-7831		6MP1	5855-432-2327		
5340-880-7831		6MP2	5855-433-2348	3	4
5355-087-2770		1A4H4	5855-433-2349	4	6
5355-087-2770	5	2	5855-433-2350	3	6
5355-409-8116		1A4H12	5855-433-2351	5	27
5355-409-8116	5	13	5855-476-6659		6MP7
5360-415-2229	5	29	5855-925-0114	4	10
5360-433-2415	5	5	5855-937-7709		1A3A1A1
5360-433-2416		1A4MP5	5930-937-2137	12	12
			5935-167-7848	9	3
			5935-167-7849	9	1

SECTION III INDEX-FEDERAL STOCK NUMBER CROSS REFERENCE
TO FIGURE AND ITEM NUMBER OR REFERENCE DESIGNATION (CONTINUED)

FEDERAL STOCK NUMBER	FIGURE NUMBER	ITEM NUMBER OR REF. DESIGNATION	REFERENCE NO.	MFG. CODE	FIG. NO	REF. DESIG. OR ITEM NO.
5935-431-3609		6A2MP1	SC-D-635053-	80063	4	2
5970-689-8832		6A2MP5	SCD635055-2	80063	12	1A2A1
5970-935-8141	9	2	SC-D-635060-	80063	9	6
6135-056-7612	6	4	SCD635060-2	80063	9	6
6135-491-5252	12	1A2A1A2	SCD635061-2	80063	12	2
6640-597-6745	1	6	SCD635061-4	80063		1A2A1A3MP1
6850-295-7685		1MP10	SCD635088	80063	12	3
6850-295-7685		1A2MP3	SCD635094-2	80063		1A1A1MP1
6850-295-7685		1A3MP17	SCD635120	80063	12	11
8030-081-2325		1A2A1MP1	SCD635146-1	80063	1	11
8030-275-8116		1A1MP22	SCD635146-2	80063	1	10
8030-275-8116		1A2A1MP3	SCD635147	80063	13	1
8030-878-9520		1A3MP16	SCD635147-2	80063		2A1MP1
8040-142-9823		1A3A1MP3	SCD635147-3	80063	13	2
8040-828-7385		1A2A1A2MP3	SCD635148-2	80063		1A5MP1
8040-855-5763		1A2A1MP2	SCD635148-3	80063		1A5MP2
9150-754-2595		1A4MP1	SCD635149	80063	14	6
			SCD635153-1	80063		5MP5
			SCD635153-2	80063		5MP6
REFERENCE NO.	MFG. CODE	FIG. NO.	REF. DESIG. OR ITEM NO.			
			SC-D-635164-1	80063	5	26
			SCD635168-2	80063	5	9
			SCD646777	80063		6A1
			SCD646778	80063		6A2
			SCD646781	80063		6MP5
			SCD646781	80063		6MP6
			SCD646783	80063		6A1MP1
			SCD646784	80063		6A1MP3
			1201	71984		6A1MP2
			93033	71984		6A1MP4
EC612	04963		1A1MP19			
LT90TYPECLASSA	81348		1A1MP21			
MILA25427	81349		5MP13			
MILB543TYPESTYLE CLASS3	81349		5MP7			
MILH9890TYPEX	81349		5MP8			
MILH9890TYPEX	81349		5MP9			
MILS522473GRADE CV	81349		1A1MP23			
MILS22473GRADE CV	81349		1A3MP18			
MILW530TYPE	81349		5MP11			
MILW530TYPE2A	81349	1	2			
MS16535-11	96906	9	7			
MS17795-22	96906		1A4A1MP6			
MS18211-3C	96906		6MP9			
MS21208C410	96906		1A2A1A3MP2			
MS21208C410	96906		1A2A1A3MP3			
NAS1453-3-0645	80205	12	17			
RTV118	01139		1A3A1A1MP4			
SCB635124	80063	12	15			
SCB635131	80063	12	8			
SCB635133-33	80063		1MP8			
SCB635133-33	80063	3	7			
SCB635151	80063		5MP4			
SC-B-635156	80063	5	6			
SCB635163	80063	5	25			
SCB635171	80063		1A4A1MP4			
SCB635171	80063		1A4A1MP5			
SCB635173	80063		1A4A1MP2			
SCB635173	80063		1A4A1MP3			
SCB645751-809	80063	14	3			
SCC607134	80063	13	4			
SCC634290-1	80063		6A2MP4			
SCC635121	80063	12	7			
SCC635122	80063	12	18			
SC-C-635144	80063	5	4			
SC-C-635169	80063	5	17			
SC-C-635175	80063	5	28			
SCC635176	80063	3	10			
SCC646782	80063	14	14			
SCC646782	80063	4	16			
SCD614697-2	80063		1A3A1A1MP1			
SCD614697-3	80063		1A3A1A1MP2			
SCD614697-3	80063		1A3A1A1MP3			

SECTION IV INDEX-REFERENCE DESIGNATION
CROSS REFERENCE TO PAGE NUMBER

REFERENCE DESIGNATION	PAGE NUMBER	REFERENCE DESIGNATION	PAGE NUMBER	REFERENCE DESIGNATION	PAGE NUMBER
MP1	2-9				
1MP4	2-6	5MP3	2-7		
1MP5	2-6	5MP4	2-7		
1MP6	2-6	5MP5	2-7		
1MP8	2-6	5MP6	2-7		
1MP10	2-7	5MP7	2-7		
1A1A1MP1	2-1	5MP8	2-7		
1A1A1MP2	2-1	5MP9	2-7		
1A1A1MP3	2-1	5MP10	2-8		
1A1A1MP4	2-1	5MP11	2-8		
1A1A1MP5	2-1	5MP12	2-7		
1A1A1MP6	2-1	5MP13	2-8		
1A1A1MP7	2-1	6MP1	2-8		
1A1MP19	2-2	6MP2	2-8		
1A1MP21	2-2	6MP5	2-8		
1A1MP22	2-2	6MP6	2-8		
1A1MP23	2-2	6MP7	2-8		
1A2A1	2-2	6MP8	2-8		
1A2A1A1	2-2	6MP9	2-8		
1A2A1MF1	2-3	6A1	2-8		
1A2A1MP2	2-3	6A1MP1	2-8		
1A2A1MP3	2-3	6A1MP2	2-8		
1A2A1A2	2-2	6A1MP3	2-8		
1A2A1A2MP3	2-2	6A1MP4	2-8		
1A2A1A3MP1	2-2	6A2	2-8		
1A2A1A3MP2	2-2	6A2MP1	2-8		
1A2A1A3MP3	2-2	6A2MP2	2-8		
1A2H3	2-3	6A2MP3	2-8		
1A2H4	2-3	6A2MP4	2-8		
1A2H5	2-3	6A2MP5	2-8		
1A2H7	2-3	6A2V1	2-8		
1A2H8	2-3	6A2V2	2-8		
1A2H9	2-3	6A2V3	2-8		
1A2MP3	2-4	6A2VM1	2-8		
1A3A1A1	2-4	6A2Y1	2-8		
1A3A1A1MP1	2-4				
1A3A1A1MP2	2-4				
1A3A1A1MP3	2-4				
1A3A1A1MP4	2-4				
1A3A1MP1	2-4				
1A3A1MP3	2-4				
1A3MP16	2-4				
1A3MP17	2-4				
1A3MP18	2-4				
1A4H2	2-5				
1A4H4	2-5				
1A4H10	2-5				
1A4H12	2-5				
1A4H16	2-6				
1A4MP1	2-6				
1A4MP3	2-5				
1A4MP5	2-5				
1A4MP10	2-6				
1A4MP11	2-6				
1A4A1	2-5				
1A4A1MP2	2-5				
1A4A1MP4	2-5				
1A4A1MP5	2-5				
1A4A1MP6	2-5				
1A5MP1	2-6				
1A5MP2	2-6				
2	2-7				
2A1MP1	2-7				
3	2-7				
4	2-7				
5	2-7				
5H1	2-7				

By Order of the Secretary of the Army:

W. C. WESTMORELAND,
General, United States Army,
Chief of Staff:

Official:

VERNE L. BOWERS,
Major General, United States Army,
The Adjutant General.

Distribution:

Active Army:

USASA (2)
CNGB (1)
Dir of Trans (1)
COE (1)
TSG (1)
ACSC-E (2)
USAMB (10)
USAIB (1)
USAARENBD (2)
USACDC (2)
USACDCCEA (1)
USACDCCEA (Ft Huachuca) (1)
USACDCIA (1)
USACDCEC (10)
CON ARC (2)
AMC (1)
MICOM (2)
TECOM (2)
MUCOM (2)
ECOM (2)
USAESC (70)
ARADCOM (2)
ARADCOM Rgn (1)
OS Maj Cored (2)
USARV (10)
USASTRATCOM (2)
Armies (1) except
7th & 8th USA (5)
1st Cav Div (2)
Ft Carson (7)
Ft Huachuca (5)
USASESS (5)
Svc Colleges (1)

Gen Dep (1)
Sig Sec, Gen Dep (5)
Sig Dep (5)
Army Dep (1) except
SAAD (30)
TOAD (14)
ATAD (10)
LBAD (7)
LEAD (7)
NAAD (3)
SVAD (3)
USAIC (2)
USAERDAA (2)
USAERDAW (2)
USACRREL (2)
Sig FLDMS (1)
Units org under fol TOE:- 2 ea.
11-35
11-36
11-37
11-39
11-95
11-117
11-158
11-215
11-216
11-500(AA-AC)
29-16
29-36
29-134
29-136
29-137

ARNG & USAR: None.

For explanation of abbreviations used, see AR 310-50.

RECOMMENDED CHANGES TO EQUIPMENT TECHNICAL PUBLICATIONS



THEN...JOT DOWN THE DOPE ABOUT IT ON THIS FORM. CAREFULLY TEAR IT OUT, FOLD IT AND DROP IT IN THE MAIL.

SOMETHING WRONG WITH PUBLICATION

FROM: (PRINT YOUR UNIT'S COMPLETE ADDRESS)

DATE SENT

PUBLICATION NUMBER

PUBLICATION DATE

PUBLICATION TITLE

BE EXACT PIN-POINT WHERE IT IS

PAGE NO.

PARA-GRAPH

FIGURE NO.

TABLE NO.

IN THIS SPACE, TELL WHAT IS WRONG AND WHAT SHOULD BE DONE ABOUT IT.

TEAR ALONG PERFORATED LINE

PRINTED NAME, GRADE OR TITLE AND TELEPHONE NUMBER

SIGN HERE

THE METRIC SYSTEM AND EQUIVALENTS

WEIGHT MEASURE

1 Centimeter = 10 Millimeters = 0.01 Meters = 0.3937 Inches
 1 Meter = 100 Centimeters = 1000 Millimeters = 39.37 Inches
 1 Kilometer = 1000 Meters = 0.621 Miles

WEIGHTS

1 Gram = 0.001 Kilograms = 1000 Milligrams = 0.035 Ounces
 1 Kilogram = 1000 Grams = 2.2 lb.
 1 Metric Ton = 1000 Kilograms = 1 Megagram = 1.1 Short Tons

LIQUID MEASURE

1 Milliliter = 0.001 Liters = 0.0338 Fluid Ounces
 1 Liter = 1000 Milliliters = 33.82 Fluid Ounces

SQUARE MEASURE

1 Sq. Centimeter = 100 Sq. Millimeters = 0.155 Sq. Inches
 1 Sq. Meter = 10,000 Sq. Centimeters = 10.76 Sq. Feet
 1 Sq. Kilometer = 1,000,000 Sq. Meters = 0.386 Sq. Miles

CUBIC MEASURE

1 Cu. Centimeter = 1000 Cu. Millimeters = 0.06 Cu. Inches
 1 Cu. Meter = 1,000,000 Cu. Centimeters = 35.31 Cu. Feet

TEMPERATURE

$5/9(^{\circ}\text{F} - 32) = ^{\circ}\text{C}$
 212° Fahrenheit is equivalent to 100° Celsius
 90° Fahrenheit is equivalent to 32.2° Celsius
 32° Fahrenheit is equivalent to 0° Celsius
 $9/5^{\circ}\text{C} + 32 = ^{\circ}\text{F}$

APPROXIMATE CONVERSION FACTORS

TO CHANGE	TO	MULTIPLY BY
Inches	Centimeters	2.540
Feet	Meters	0.305
Yards	Meters	0.914
Miles	Kilometers	1.609
Square Inches	Square Centimeters	6.451
Square Feet	Square Meters	0.093
Square Yards	Square Meters	0.836
Square Miles	Square Kilometers	2.590
Acres	Square Hectometers	0.405
Cubic Feet	Cubic Meters	0.028
Cubic Yards	Cubic Meters	0.765
Fluid Ounces	Milliliters	29.573
its	Liters	0.473
arts	Liters	0.946
allons	Liters	3.785
Ounces	Grams	28.349
Pounds	Kilograms	0.454
Short Tons	Metric Tons	0.907
Pound-Feet	Newton-Meters	1.356
Pounds per Square Inch	Kilopascals	6.895
Miles per Gallon	Kilometers per Liter	0.425
Miles per Hour	Kilometers per Hour	1.609

TO CHANGE	TO	MULTIPLY BY
Centimeters	Inches	0.394
Meters	Feet	3.280
Meters	Yards	1.094
Kilometers	Miles	0.621
Square Centimeters	Square Inches	0.155
Square Meters	Square Feet	10.764
Square Meters	Square Yards	1.196
Square Kilometers	Square Miles	0.386
Square Hectometers	Acres	2.471
Cubic Meters	Cubic Feet	35.315
Cubic Meters	Cubic Yards	1.308
Milliliters	Fluid Ounces	0.034
Liters	Pints	2.113
Liters	Quarts	1.057
ers	Gallons	0.264
ms	Ounces	0.035
ograms	Pounds	2.205
Metric Tons	Short Tons	1.102
Newton-Meters	Pounds-Feet	0.738
Kilopascals	Pounds per Square Inch	0.145
ometers per Liter	Miles per Gallon	2.354
ometers per Hour	Miles per Hour	0.621



PIN: 018622-000